

# Van Buren County Land Bank Authority

## Request for Proposal General Contractor - Abatement & Building Stabilization

(Openings, Foundations, Structure, and Masonry Restoration)

At:

5 W Main Street  
Hartford, MI 49057

Addendum #2 – 2/20/2026

In original RFP, dated 11/3/25, responses were due on 11/21 and then delayed without a due date with Addendum #1 on 11/17/25. Please reference the original RFP dated and exterior stairway drawings as an attachment with further clarification.

The new bid due date is now: **03/16/2026 at 10am at the Van Buren County Land Bank Office**. Please reach out to Amelia at The Barton Group with any questions 269-823-3572. There is no physical access to the 2<sup>nd</sup> story unless a contractor rents a lift or uses a ladder at their own risk and expense. Visual inspections from the outside can occur, and there is no official pre-bid walk through.

## Scope of Work: Stabilization & Access February 2026

Please see attached stairway access drawings from WLP A/E and plan to construct as drawn.

General contractor to provide adequate safety, disposal of materials (per local and state regulations), building permit, and restroom facilities as needed on the jobsite. Abonmarche will provide guidance on their structural recommendations, and the stairwell plans are construction documents.

### 1. Openings – Doors & Windows

- **Objective:** Remove and dispose of existing, dysfunctional openings and install new doors and windows to ensure proper functionality and security.
- **Tasks:**
  - Follow original RFP instructions and requirements as well as further details in WLP's documents (1 ground level steel door with half lite on east side and 1 ground level half lite steel door on north side at slightly raised stairwell)
  - 1 upper level door on the east side into stair tower
    - Remove and dispose of existing door and related material completely. Furnish and install new steel, pre-hung, insulated door as manufactured by Therma Tru, "Profiles" SERIES 24-Gauge #255HD or similar. New steel door to have a minimum 10-year warranty. Recommend northern climate energy star rated doors. Installation to include new weatherstripping, threshold, kickplates, and push/pull hardware.
  - Replace two exposed openings on East side with windows with specifications from original RFP
  - Fill in obsolete, exterior door on west end of north side and two obsolete windows on north side with decorative, insulated metal panel
  - Replace three exposed, 2<sup>nd</sup> story openings (2 existing windows and 1 steel door) on north side with windows to match with specifications from original RFP



## 2. Access & Stability

- **Objective:** Create a stable building (reference structural drawings and report by Abonmarche 2025 and WLP A/E's stairway tower permit drawing set)
- **Tasks:**
  - Follow original RFP instructions
  - Follow WLP's construction drawings for the construction of a stairwell tower to access 2<sup>nd</sup> floor
    1. Electrical and HVAC to be installed as drawn
      - Keycard/fob access to be wired for stair tower exterior door
    2. Fire suppression to be installed as necessary per fire suppression subcontractor and local building authority

## 3. Junk Removal

- **Objective:** Create a safe work environment and a cleaned out space that will not attract mold, rodents or pests.
- **Tasks:**
  - Remove and recycle (when possible) appliances, household belongings, ruined cabinetry, obsolete ceiling grid, furniture, carpet, and other assorted items on both floors

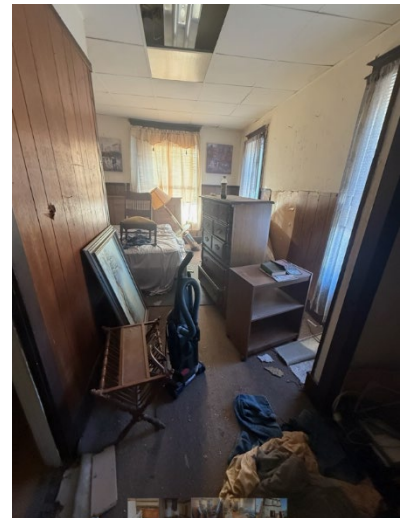
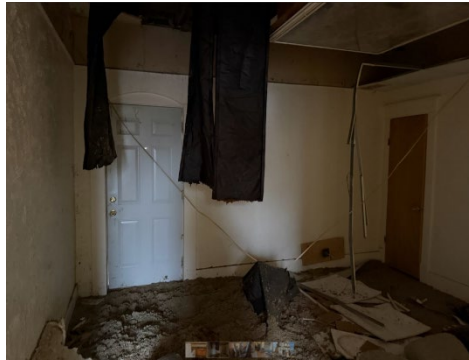

### **Bid Form - Stabilization for 5 W Main Street Hartford, MI**

The undersigned hereby declares that the instructions and specifications, including all appendices, have been carefully examined and that the windows, doors, foundation, tuck pointing, and structural sound framing for 5 W Main Street Hartford, MI, will be done for the prices set forth in this bid. It is understood and agreed that all bid prices shall remain in effect for at least sixty (60) days from the date of the bid opening to allow for the award of the bid and that if chosen the bid price remains firm. The undersigned bidder further agrees and understands that Van Buren County reserves the right to reject any and/or all bids and the right to waive irregularities in bidding if it determines such action to be in the best interest of Van Buren County.

Bidding Company	
Address/City/State/Zip	
Phone and E-mail	
Authorized Representative/Title	
Signature	
Date	

Cost to complete the general requirements and scope of work (including bond, insurance, fee, general conditions, supervision, and subcontractor work)	
5 W Main Street Hartford, MI	\$

#### **Please check the following:**

- I acknowledge that the work for stabilization will be furnished within a maximum of 24 weeks from contract execution
- I acknowledge that we are not listed on any governmentwide exclusion list and further have not been debarred, suspended, or otherwise excluded by agencies or declared ineligible under statutory or regulatory authority. Further, I acknowledge that the VBCLBA will be conducting a search to confirm.
- I acknowledge that Davis-Bacon prevailing wages apply to the scope of this RFP and that a prevailing wage determination in accordance with statute requirements and original Appendix has been included as part of my bid pricing.
- I acknowledge receipt of Original RFP, Addendum No. 1 and Addendum No. 2.

**Additional Questions required to complete the Bid Form. Information to be provided in a supplemental document.**

1. How is your company organized (corporation, partnership, etc.) and how long have you been in business? List the name and contact information of the owner, president, managing partner, or CEO.
2. Please provide the name and work experience of the Project Manager you are assigning to this contract. This Project Manager will be the main contact for the county and will oversee contract compliance, timeliness, and work quality.
3. Has your company had a similar contract terminated for cause within the last three years? If yes, please explain.
4. Has your company received any violations in the last five years? If yes, please list and explain how the violations were resolved.
5. Include a proposed, detailed work schedule.
6. Attach a list of proposed subcontractors. List of subcontractors (company name, address, phone, email, and all owner/principal name(s)) and the tasks for which they will be used. The VBLBA will determine whether each proposed subcontractor is eligible to do business on a federally funded contract and will inform the contractor if any are ineligible.
7. Attach a breakdown of the work cost (sworn statement estimate or separated by division or work category).
8. Attach a bid bond.

I hereby state that I have the authority to submit this Proposal on behalf of the undersigned. I hereby state that I have not communicated with, nor accepted anything of value from, any official or employee of Van Buren County regarding this Request for Proposals.

This Bid is Presented By:

\_\_\_\_\_  
Company Name

\_\_\_\_\_  
Authorized By (Printed Name/Title)

\_\_\_\_\_  
Authorized Signature

\_\_\_\_\_  
Date

## Non-Iran Business Certification

Pursuant to Michigan law (Iran Economic Sanctions Act, Michigan PA 517 of 2012), before accepting any bid or proposal or entering into any contract for goods and services with any prospective vendor, the County must obtain certification from the vendor that it is not an "Iran-Linked Business."

By signing below, I certify and agree on behalf of the company submitting this form and myself the following: (1) that I am duly authorized to legally bind the company submitting this proposal; (2) that the company submitting this proposal is not an "Iran Linked Business," as that term is defined in Section 2(E) of the Iran Economic Sanctions Act, Michigan PA 517 of 2012; and (3) that I and the company submitting this proposal will immediately comply with any further certifications or information submissions requested by the county in this regard.

---

Company Name

---

Authorized By (Printed Name/Title)

---

Authorized Signature

---

Date

Request for Proposal – Addendum #2  
General Contractor – Stabilization Activities

Request for Proposal – Addendum #2  
General Contractor – Stabilization Activities

**Attachment 1 – WLP A/E Stairway & Access Permit Drawing Set**





ISSUED FOR	
DATE	DESCRIPTION

Revision Schedule		
No.	Date	Description

Drawn by: Author

**EXTERIOR ELEVATIONS**

SCALE: AS NOTED

Sheet No.  
**A1.1**

Project No.  
**25-089**

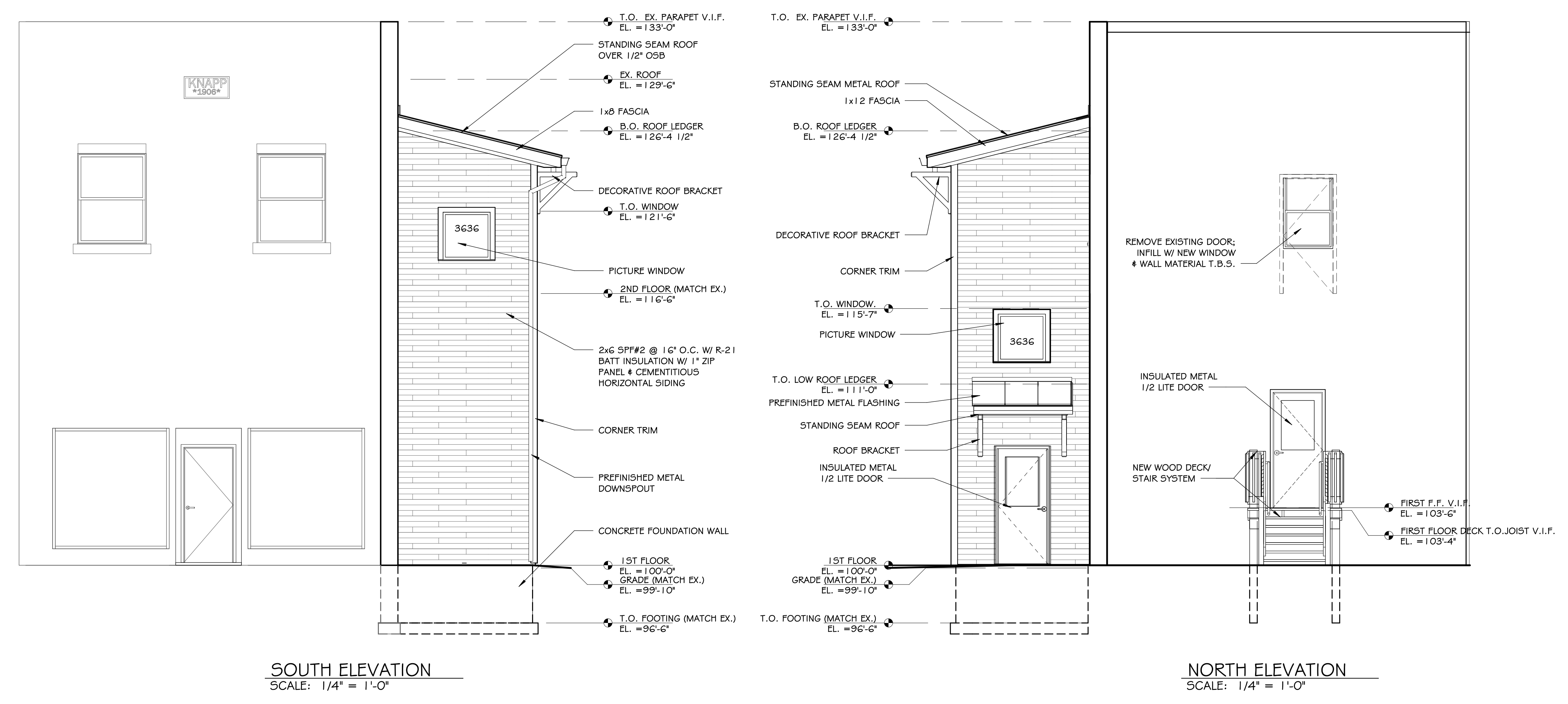

**SOUTH ELEVATION**  
 SCALE: 1/4" = 1'-0"

**NORTH ELEVATION**  
 SCALE: 1/4" = 1'-0"

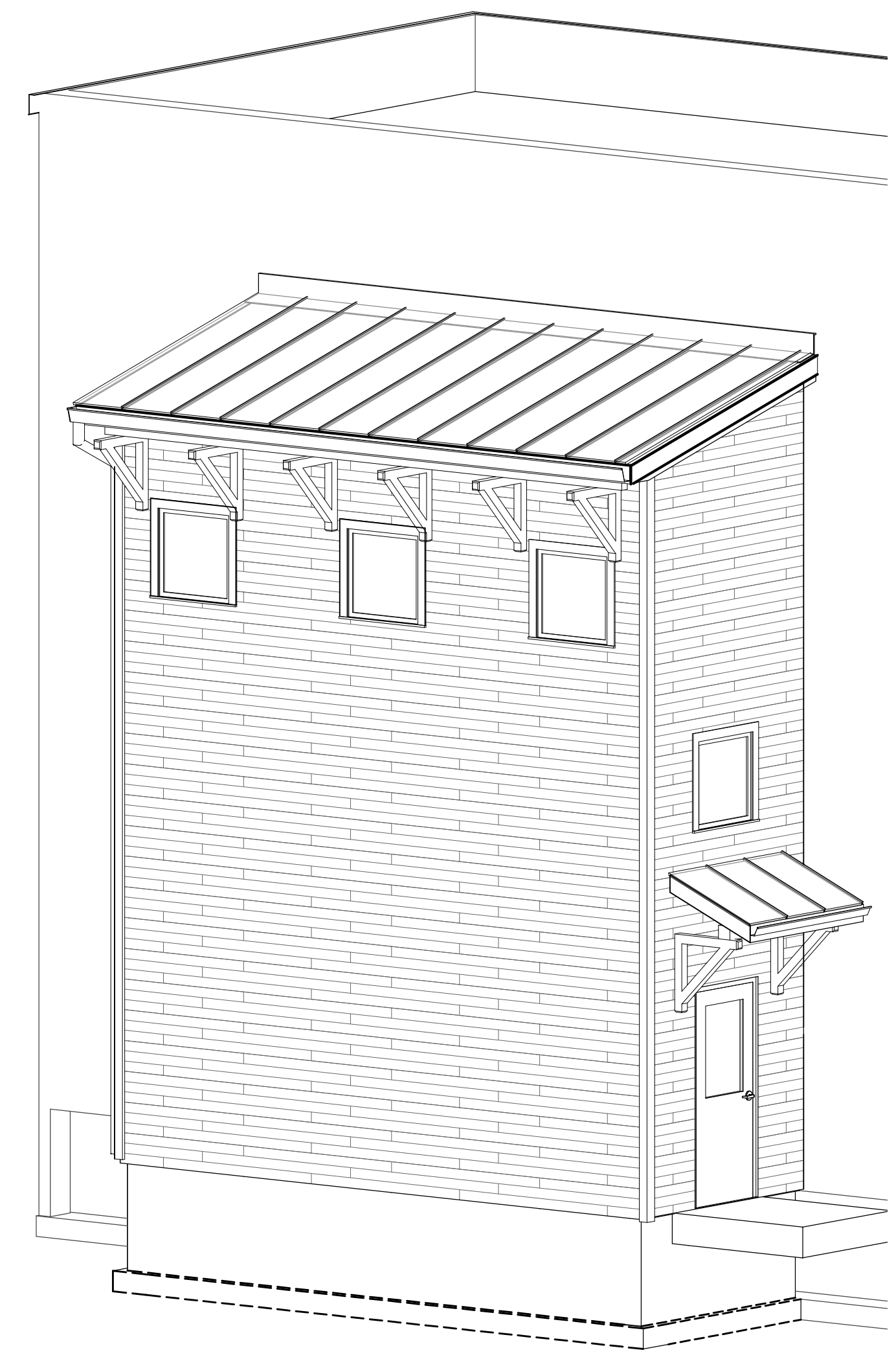

**4 STAIR TOWER AXON**  
 SCALE:

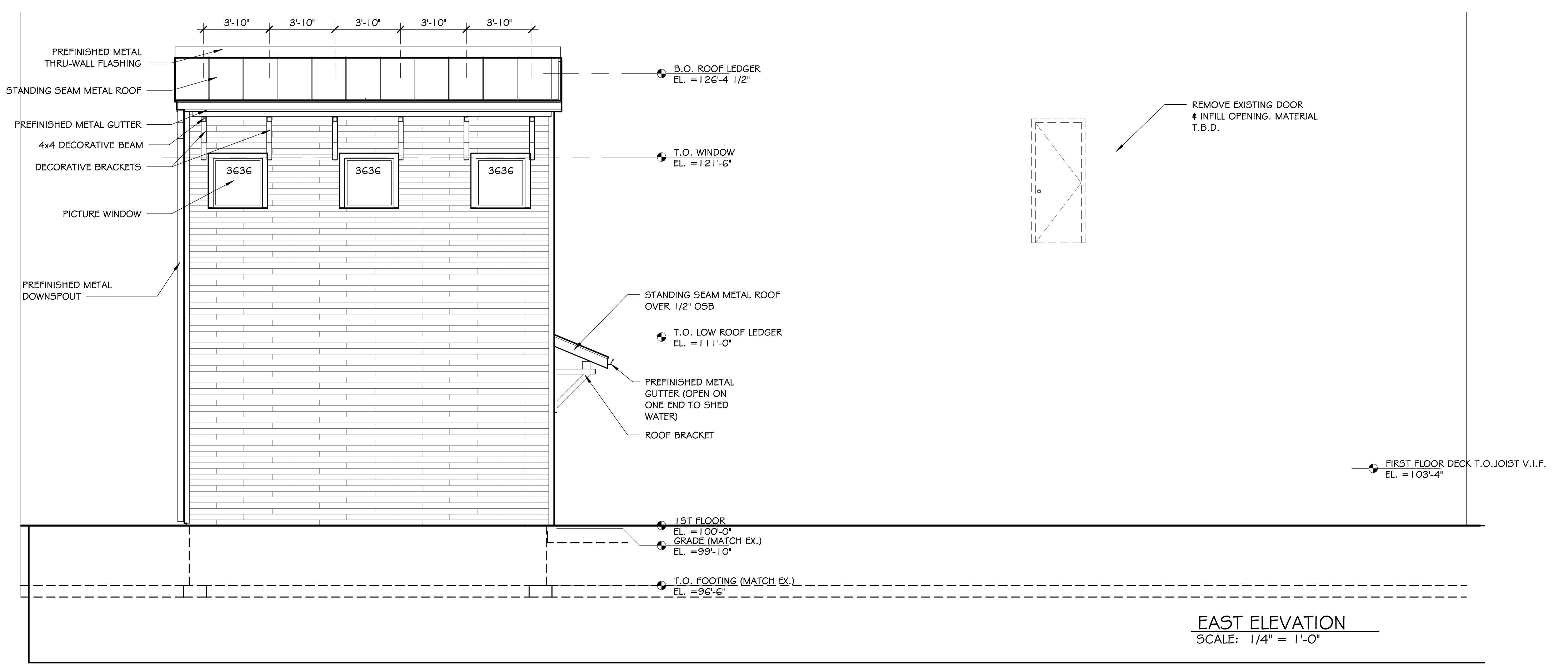

**EAST ELEVATION**  
 SCALE: 1/4" = 1'-0"





ISSUED FOR	
DATE	DESCRIPTION

Revision Schedule		
No.	Date	Description

Drawn by: JCH

**STAIR SECTIONS/ DETAILS**

SCALE: AS NOTED

Sheet No.  
**A2.4**

Project No.  
**25-089**

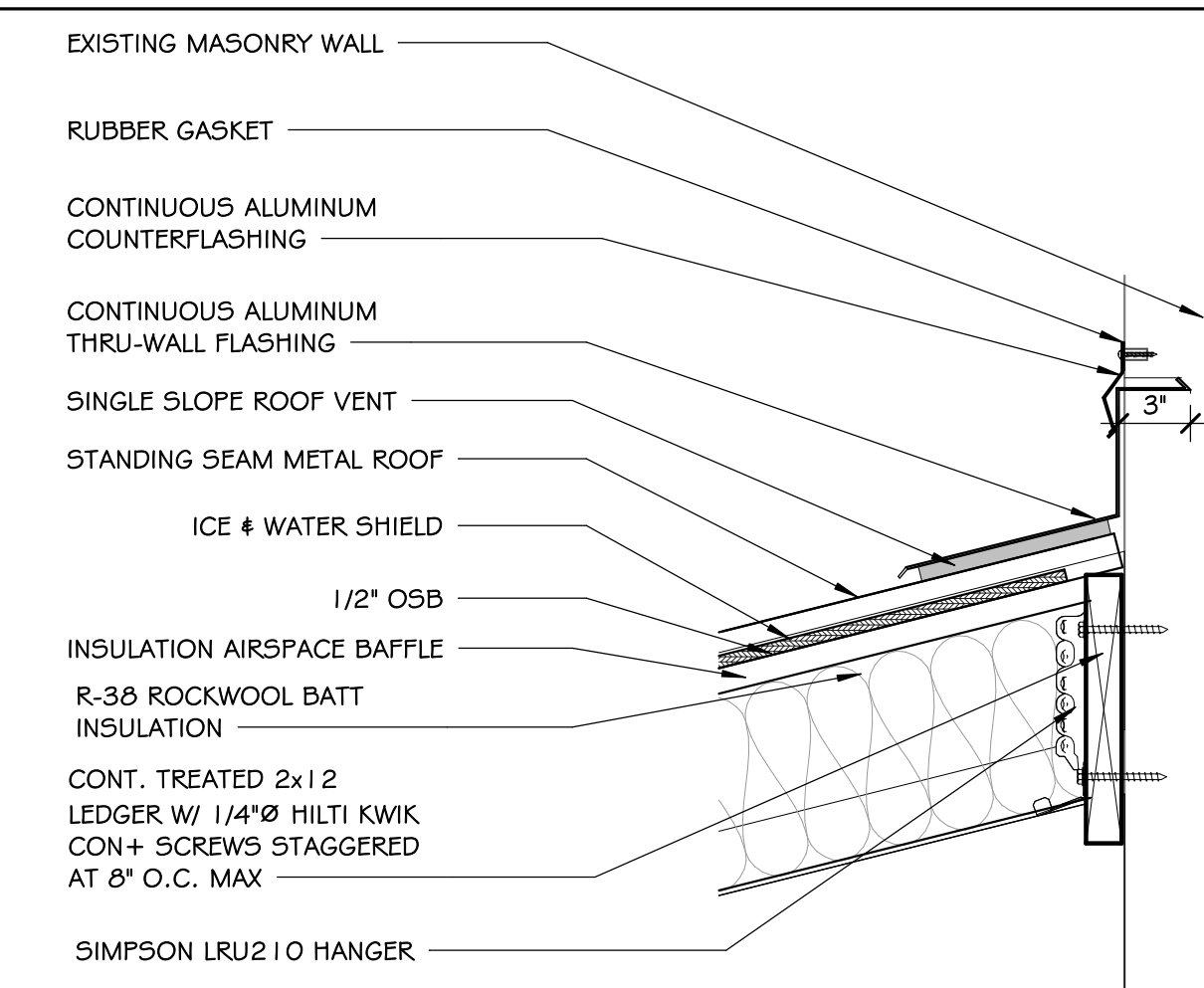

**9 ROOF TO EX. WALL CONNECTION**  
 A2.4/A2.4 SCALE: 1 1/2" = 1'-0"

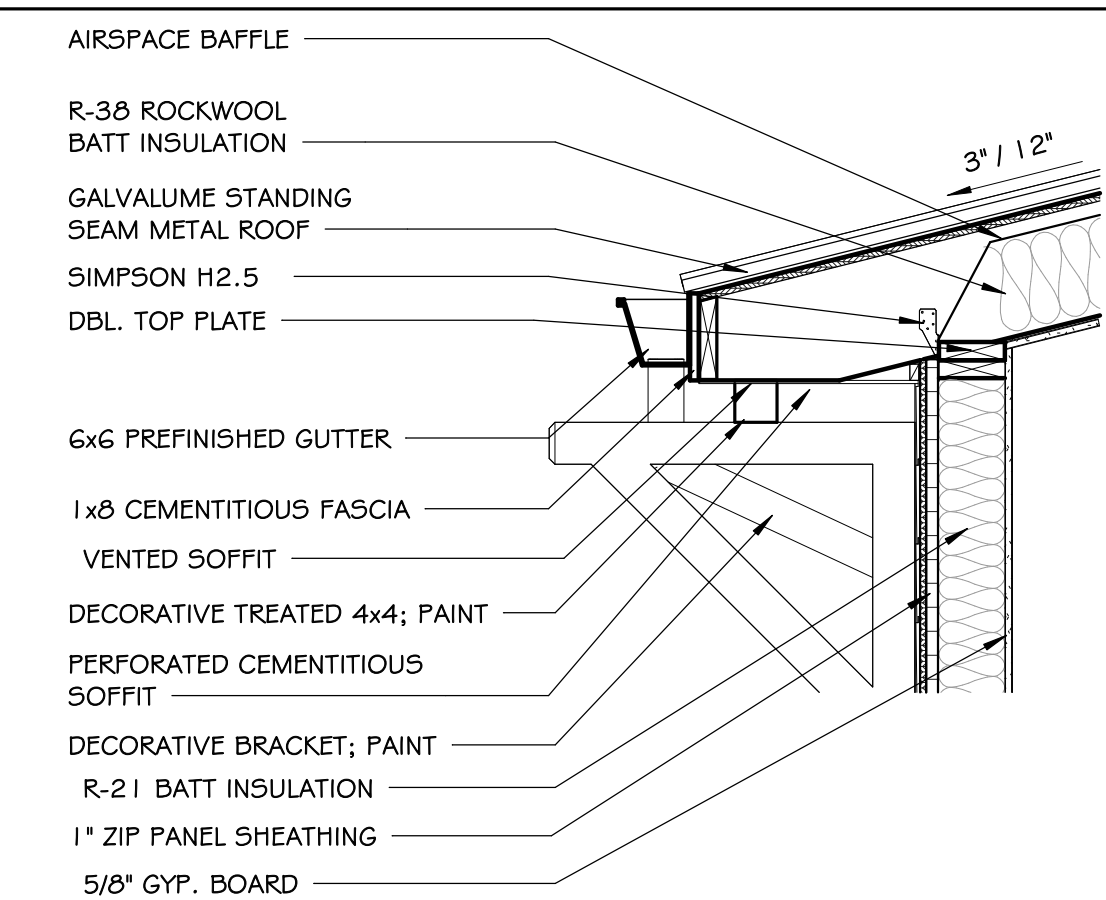

**6 ROOF JOIST TO WALL DETAIL**  
 A2.4/A2.4 SCALE: 3/4" = 1'-0"

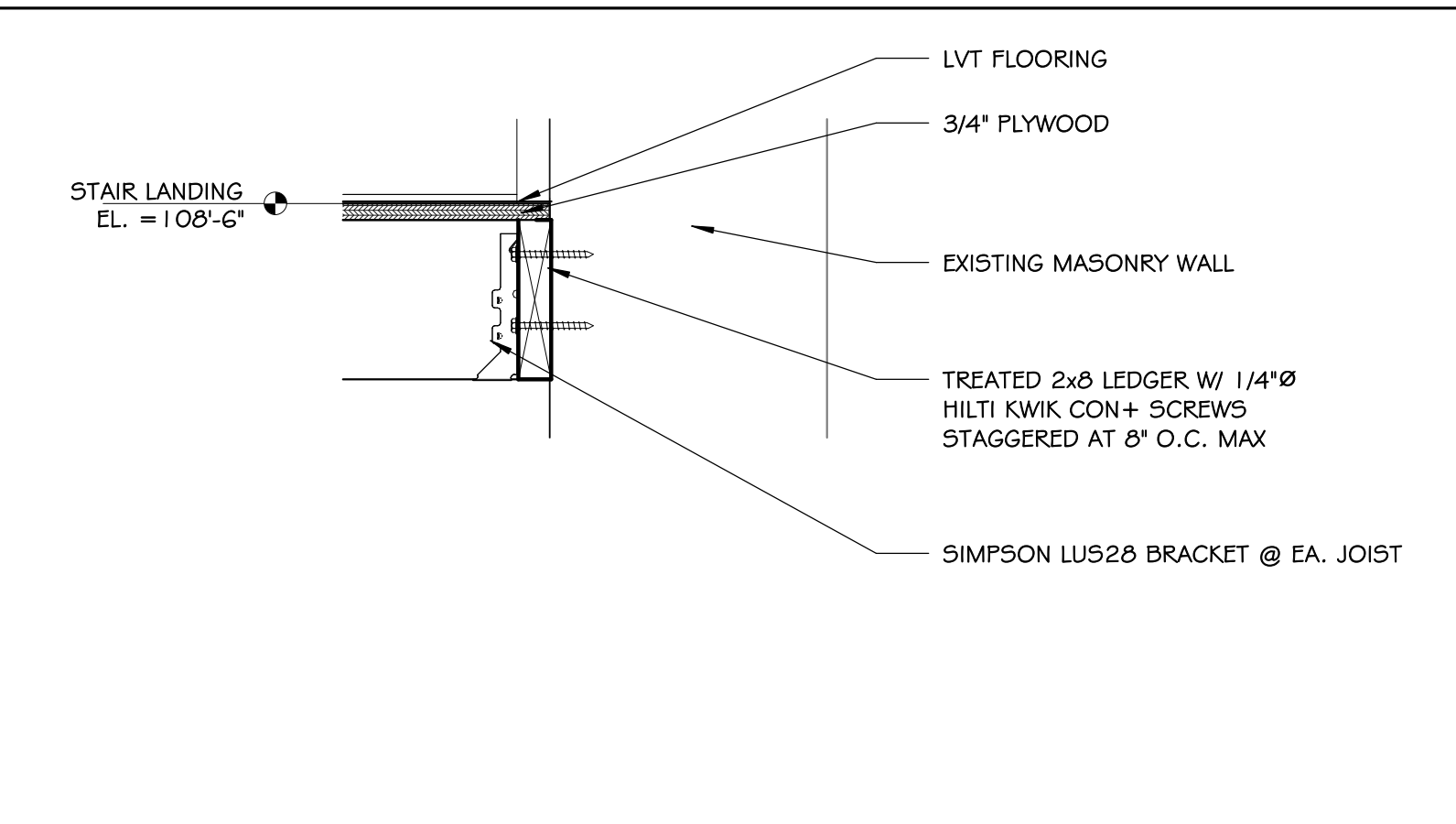

**7 LEDGER CONNECTION**  
 A2.4/A2.4 SCALE: 1 1/2" = 1'-0"

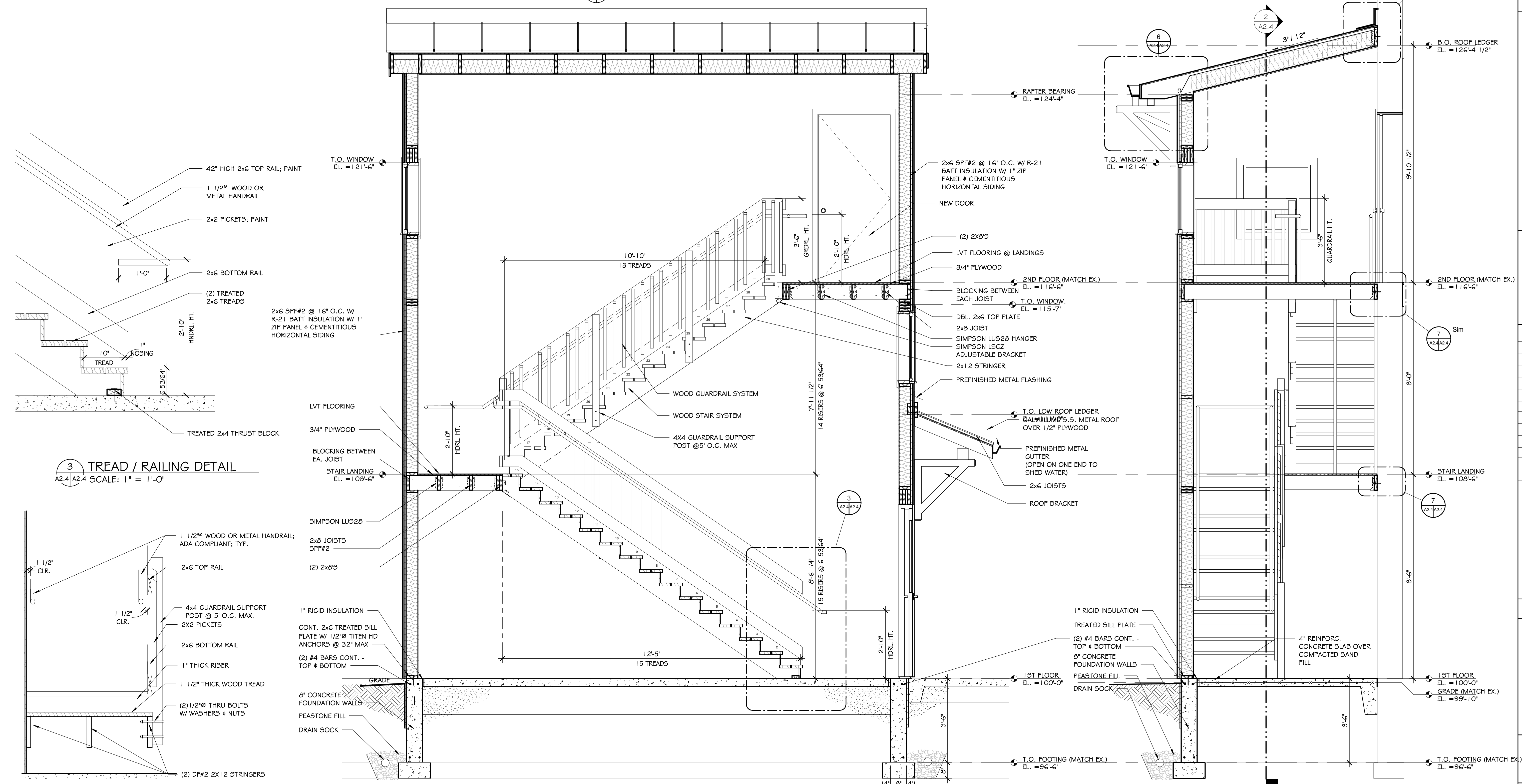

**2 STAIR SECTION B**  
 A2.2/A2.4 SCALE: 1/2" = 1'-0"

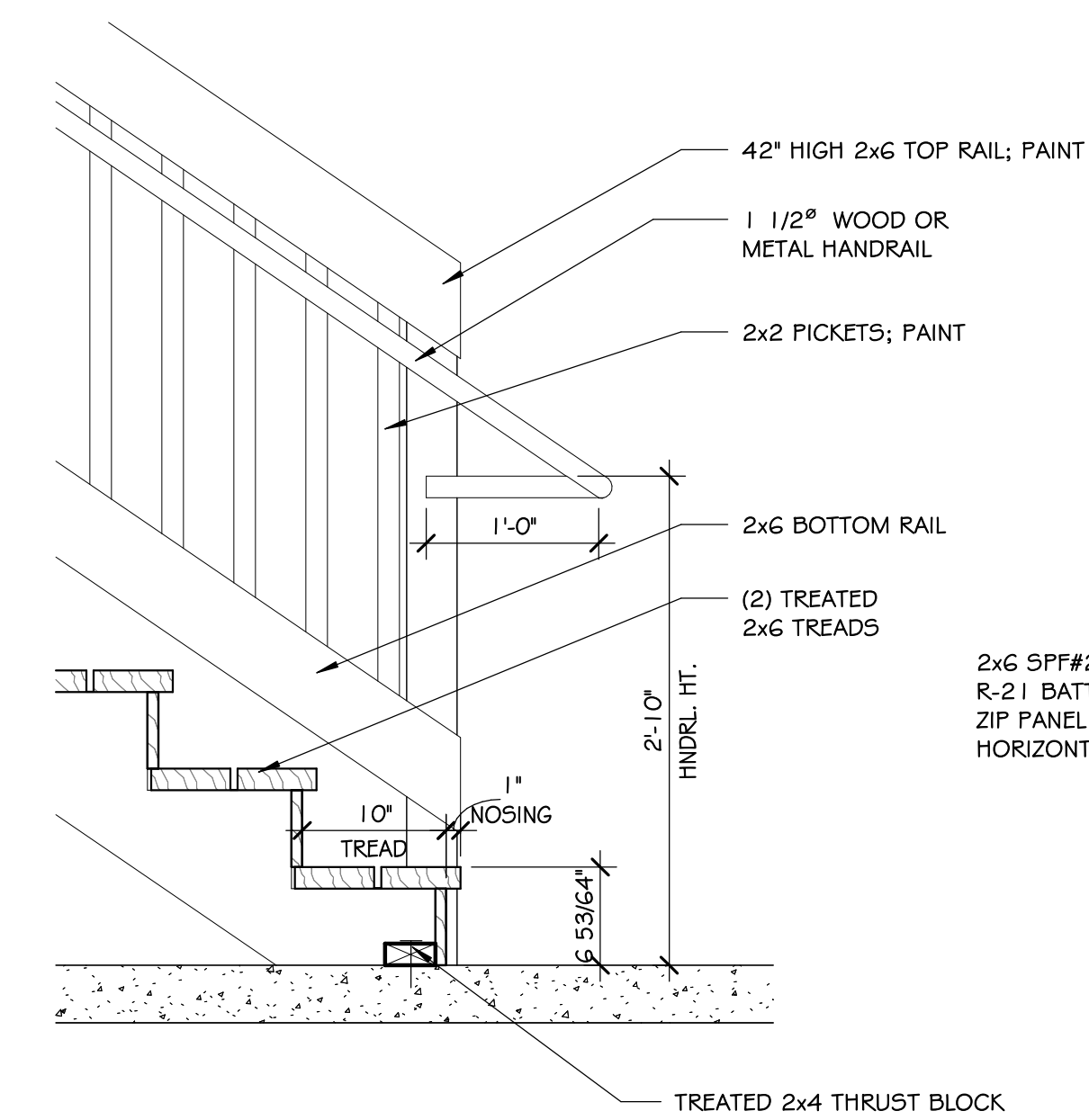

**3 TREAD / RAILING DETAIL**  
 A2.4/A2.4 SCALE: 1" = 1'-0"

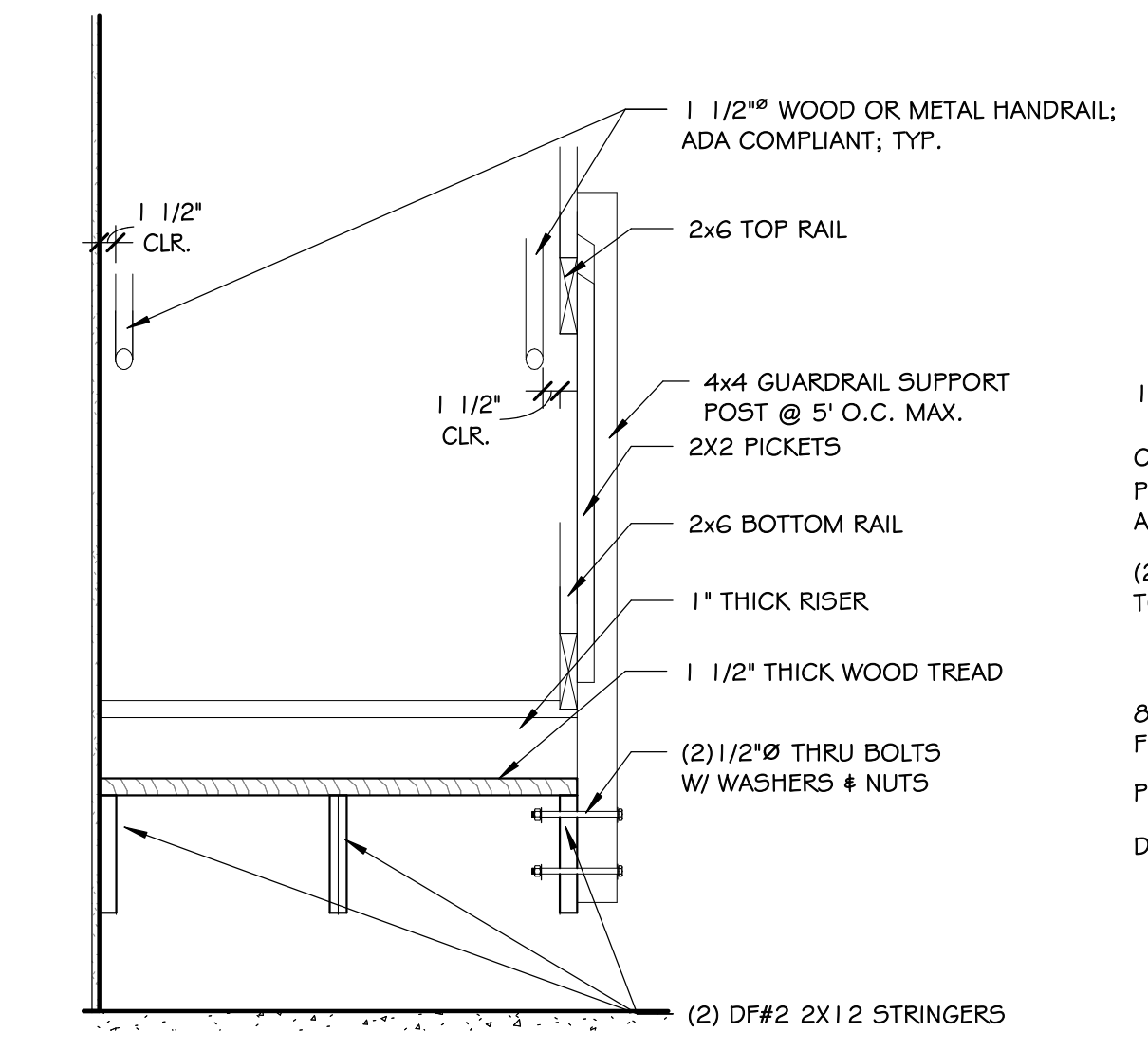

**8 RAILING SECTION**  
 A2.2/A2.4 SCALE: 3/4" = 1'-0"

S:\DWG\25089\_VBCLB\_Hartford Stair Tower\REV\BARTON GROUP 5TH MAIN STREET STACKED STAIR.rvt





